

PRODUCT: 78G 30" BED FRAME

GENERAL

APPLICATION: TWIN (3/3, 3/0)

FINISH: BROWN

MOBILITIES (LEG ATTACHMENTS): (4) 2" GLIDES

PACKAGED WEIGHT: 19 LBS.

UPC CODE: 094325171965 (3)

CONSTRUCTION

SIDE RAIL: 1 1/4 X 1 1/4 X 63 X .100

CROSS ARMS: 1 X 1 X 12GA.

TYPE: CLAMP

CROSS WIRE/SUPPORT: N/A

CENTER SUPPORT: NONE

RETAINER BRACKETS: N/A

HEADBOARD/FOOTBOARD BRACKETS: BOLT ON

REMARKS:

ALL FASTENERS PER ANSI B18 AND SAE J429 STANDARDS			C	1) WAS 20101300 (SHT 2) 2) WAS 21770100 (SHT 2) 3) ADDED UPC (SHT 1) * REV B ON EDR 10497 *	RAB	SDS	10634	10-04-07
ALL WELDS PER ANSI/AWS A2.4-79 AMERICAN NATIONAL STANDARD								
DIMENSIONS ARE INCHES UNLESS OTHERWISE NOTED			REV. LEVEL	DESCRIPTION	AUTHOR	CHKD	EDR#	DATE
TOLERANCE UNLESS OTHERWISE NOTED			APPROVALS	NAME	DATE	 78G 30" FRAME		
DECIMAL:	FRACTIONAL:	ANGULAR:	DRAWN	N/A	N/A			
.XXX = ±.015 .XX = ±.03 .X = ±.06	± 1/32	± 1°	TOOLING	N/A	N/A			
PROPRIETARY AND CONFIDENTIAL			MFG APPR.	N/A	N/A			
THE INFORMATION CONTAINED IN THIS DRAWING IS THE SOLE PROPERTY OF LEGGETT & PLATT, INC. ANY REPRODUCTION IN PART OR AS A WHOLE WITHOUT THE WRITTEN PERMISSION OF LEGGETT & PLATT, INC. IS PROHIBITED.			Q.A.	N/A	N/A			
			THIS PRINT SUPERSEDES ALL PREVIOUS PRINTS			DESTROY ALL PRINTS ISSUED PRIOR TO THIS REVISION		
			SIZE	DWG. NO.		420536		
			SCALE:1:12		DO NOT SCALE DRAWING		SHEET 1 OF 3	

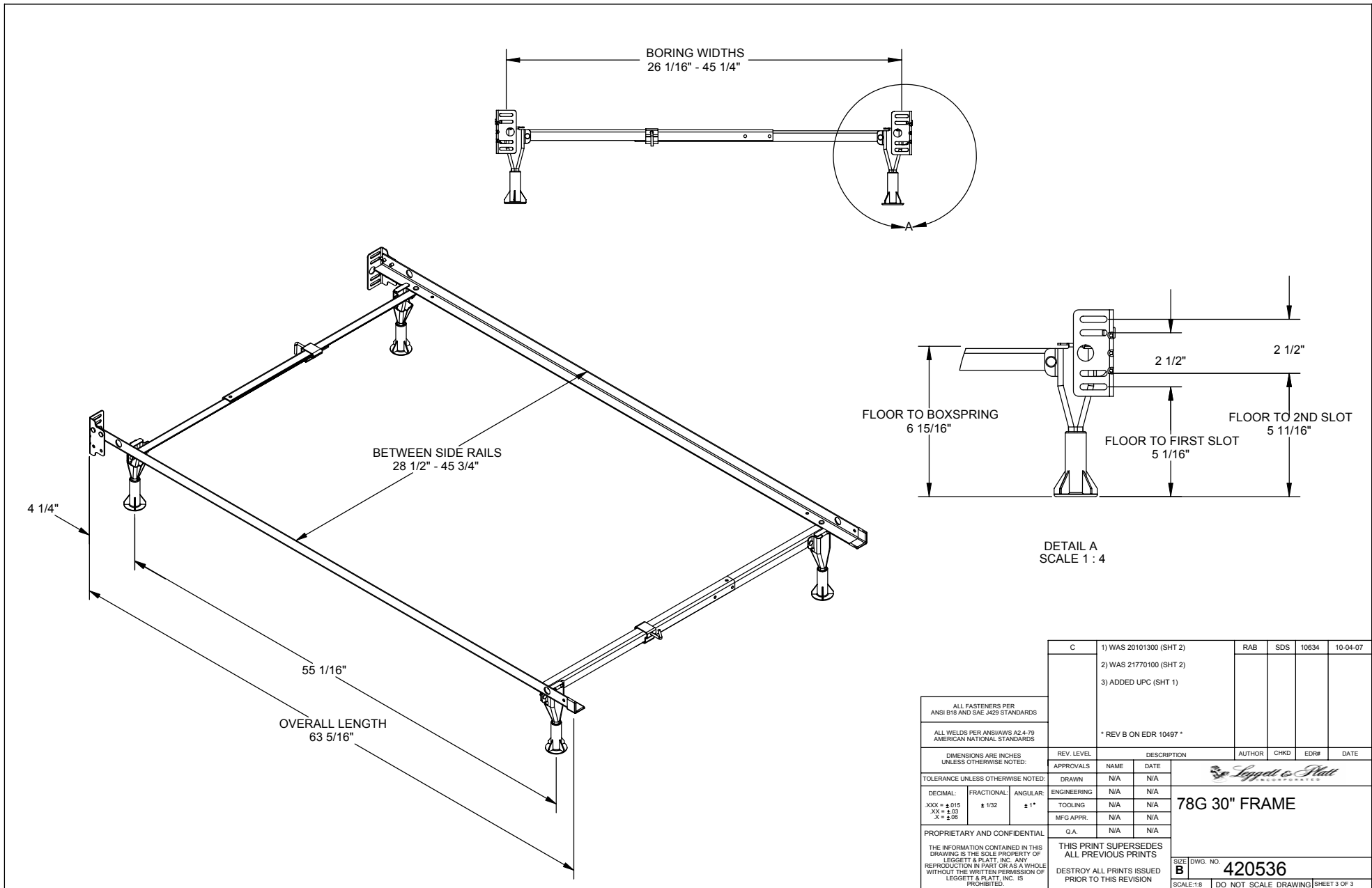

ALL FASTENERS PER ANSI B18 AND SAE J429 STANDARDS ALL WELDS PER ANSIAAWS A2.4-79 AMERICAN NATIONAL STANDARDS DIMENSIONS ARE INCHES UNLESS OTHERWISE NOTED. TOLERANCE UNLESS OTHERWISE NOTED: DECIMAL: .XXX = ±.015 .XX = ±.03 .X = ±.06 FRACTIONAL: ± 1/32 ANGULAR: ± 1° PROPRIETARY AND CONFIDENTIAL THE INFORMATION CONTAINED IN THIS DRAWING IS THE SOLE PROPERTY OF LEGGETT & PLATT, INC. ANY REPRODUCTION IN PART OR AS A WHOLE WITHOUT THE WRITTEN PERMISSION OF LEGGETT & PLATT, INC. IS PROHIBITED.	C	1) WAS 20101300 (SHT 2)	RAB	SDS	10634	10-04-07
		2) WAS 21770100 (SHT 2)				
		3) ADDED UPC (SHT 1)				
		* REV B ON EDR 10497 *				
	REV. LEVEL	DESCRIPTION	AUTHOR	CHKD	EDR#	DATE
	APPROVALS	NAME	DATE			
	DRAWN	N/A	N/A			
	ENGINEERING	N/A	N/A			
	TOOLING	N/A	N/A			
	MFG APPR.	N/A	N/A			
	Q.A.	N/A	N/A			
	THIS PRINT SUPERSEDES ALL PREVIOUS PRINTS DESTROY ALL PRINTS ISSUED PRIOR TO THIS REVISION					
	SIZE	DWG. NO.	SCALE: 1:8			
	B	420536	DO NOT SCALE DRAWING SHEET 3 OF 3			

Leggett & Platt
78G 30" FRAME