

# Q31 LOW PROFILE ASSEMBLY INSTRUCTIONS

**Figure 1**

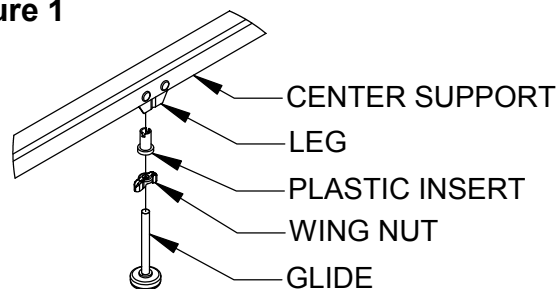

**Step 1:** Tap PLASTIC INSERTS into LEGS. With flat surface up, screw WING NUTS onto GLIDES. Thread GLIDES into PLASTIC INSERTS. See Figure 1.

**Figure 2**

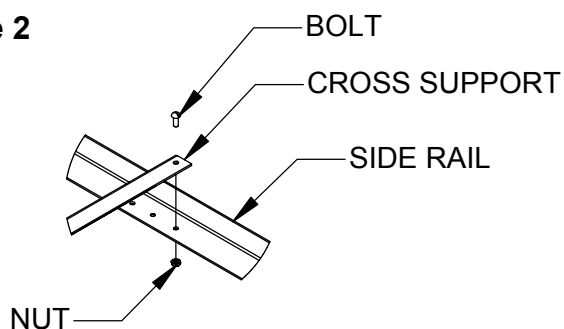

**Step 2:** Attach CROSS SUPPORTS to SIDE RAILS with NUTS and BOLTS as shown in Figure 2.

**Figure 3**

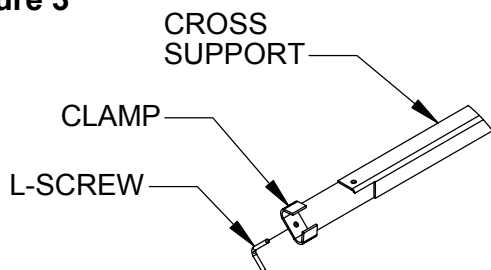

**Step 3:** Loosely attach L-SCREWS to CLAMPS and slide CLAMPS onto CROSS SUPPORTS as shown in Figure 3.

**Figure 4**

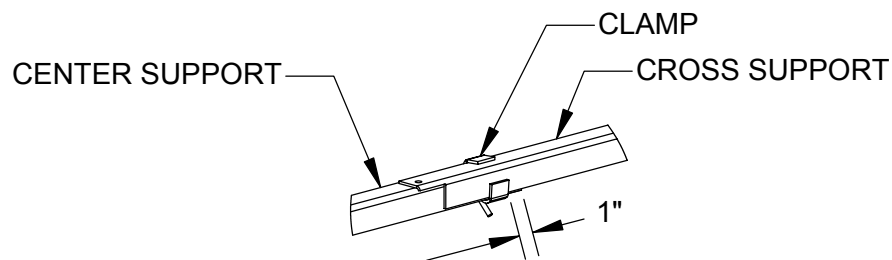

**Step 4:** Place CENTER SUPPORT under CROSS SUPPORTS in the center of the bed. Slide CLAMPS onto overlapped CROSS/CENTER SUPPORTS. Position each CLAMP one inch from the edge of the lower CROSS SUPPORT as shown in Figure 4.

**Step 5:** Adjust glides so that they touch the floor. Tighten wing nuts against plastic inserts.

**Note:** *There must be at least one inch of the glide stem in the plastic insert.*

**Step 6:** Assembled product should resemble product shown in Figure 5. Tighten all nuts, bolts, and L-screws.

**Figure 5**

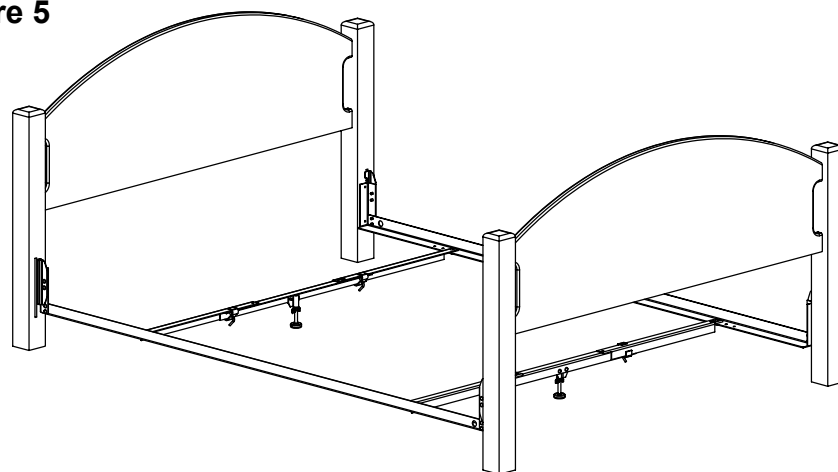

*Leggett & Platt*  
INCORPORATED

DATE  
5-06-04

DWG. NO. **99300016**

DO NOT SCALE DRAWING

SHEET 1 OF 1