

PLX-18 Leg Extension Kit Installation Instructions

Tools Required

- 7/16" Wrench
- Flashlight
- Adjustable Wrench
- Tape Measure

Please remove your mattress and box spring from the bed before installation. This will make installation of the PLX-18 Leg Extension Kit easier and safer. Do not attempt to move the mattress by yourself, get help.

1. Determine the height from the floor to the bottom of the boxspring.
 - 1.1. For heights of 11"-14", bolt the leg extension to the leg of the bed, using the hole positioned at the TOP of the leg. See View 1.
 - 1.2. For heights of 14"-18", bolt the leg extension to the leg of the bed using the hole positioned at the BOTTOM of the leg. See View 2.
2. Tap your existing glide assembly into leg extension in the same fashion that it was originally assembled to the bed frame.
3. After bed frame/rail and cross supports have been fully assembled and secured, adjust glide height to clear floor or carpet surface by ¼ inch. Tighten the glides to secure them in place.

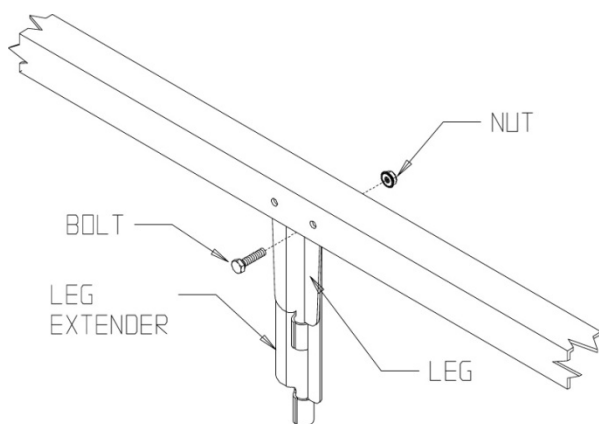

View 1

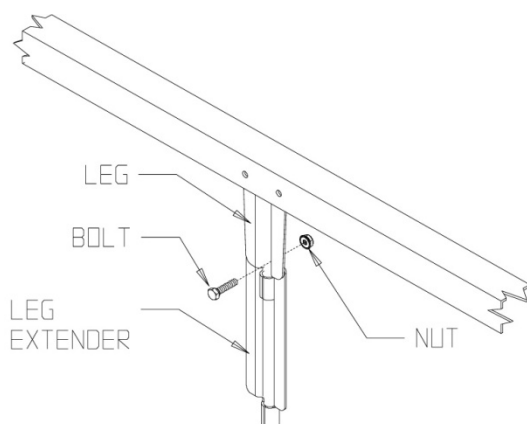

View 2

