

**IL-1
INSTRUCTION SHEET**

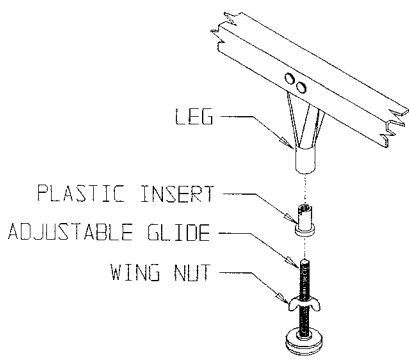

View 1

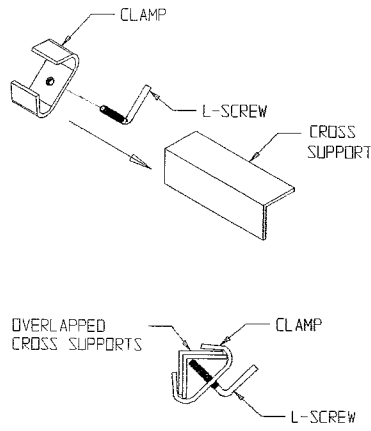

View 2

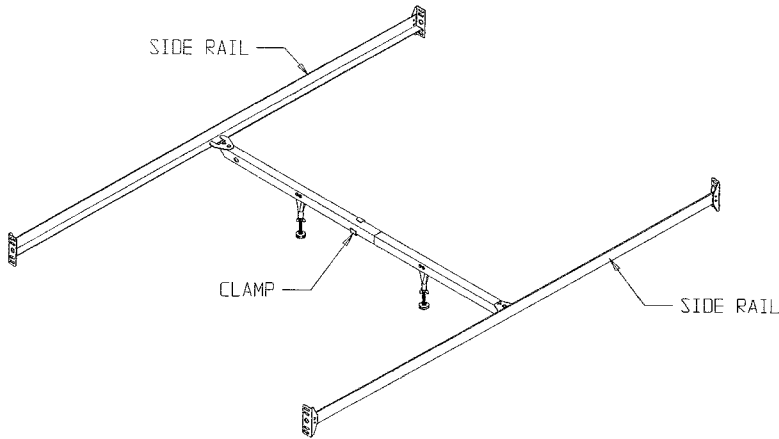

View 3

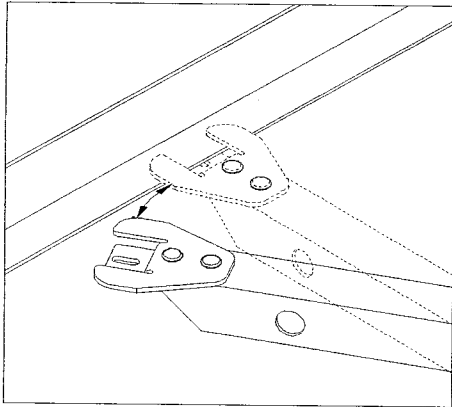

View 4

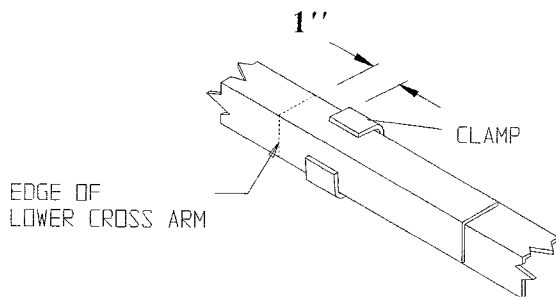

View 5

Step 1 Tap plastic inserts into legs of cross support.

Step 2 Thread wing nuts, with flat surface up, about 2/3 of the way onto adjustable glide. Thread adjustable glides about 1/2 way up into leg. See View 1.

Step 3 Loosely attach L-screw to clamp and slide onto end of the cross support as indicated in View 2. Overlap cross supports and slide clamp onto both cross supports.

Step 4 Center cross support between side rails as shown in View 3.

Step 5 Slide the cross support onto side rails, as shown in View 4. Position clamp one inch from the end of the lower cross arm as detailed in View 5 and tighten L-screw.

Step 6 Adjust glide height to clear floor or carpet surface by 1/8 inch. Lock glides in place by turning wing nuts tight against the plastic inserts.

P.N. 99300628

- 10/12/01